

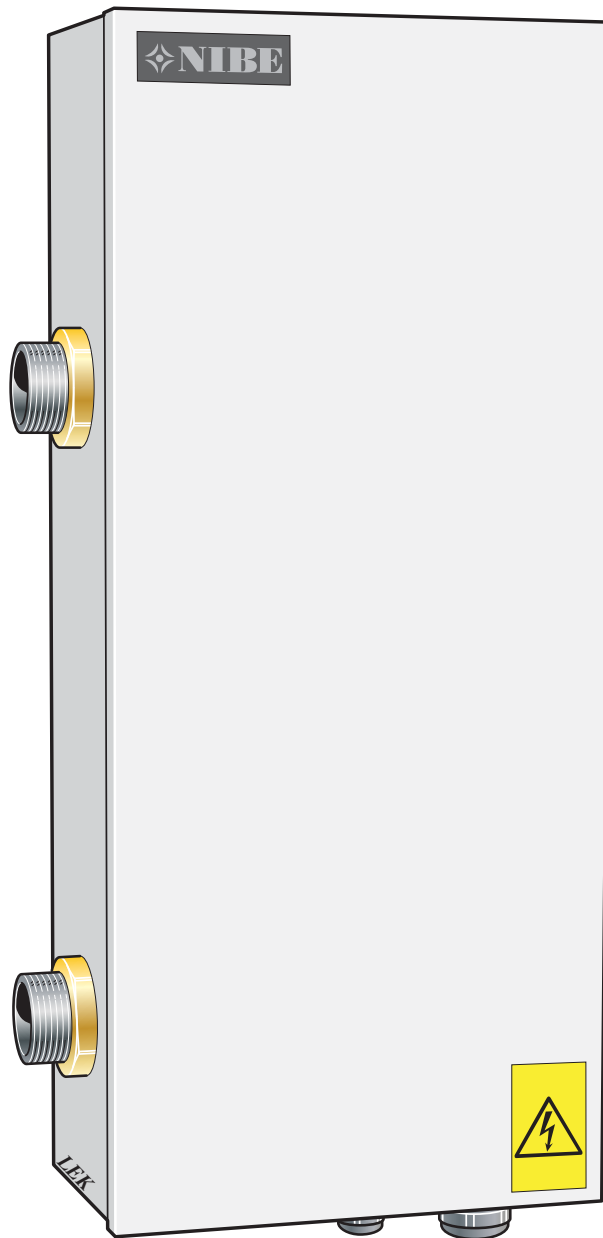

MOS GB 1238-4  
ELK 15  
031179

INSTALLATION AND MAINTENANCE INSTRUCTIONS

# ELK 15





## For Home Owners

### General

#### System description

Principle of operation	3
Components	3
System diagram	3

#### Operation and maintenance

General	4
Operation	4
Safety valve	4
Venting	4
Draining	4
Actions in the event of freeze risk	4

## For the Installer

### General information for the installer

Function	5
Pipe installation	5

Electrical installation	5
Draining	5

### Installation alternative

Components	6
FIGHTER 1320/1330 and F1330	7
F1345	10

### Miscellaneous

#### Electrical circuit diagram

To F1145	12
ELK 15	13

#### Technical specifications

Dimensions	14
Component positions	15
List of components	15
Technical specifications	16

#### Dealing with malfunctions

Low room temperature	17
----------------------	----

## General

***In order to get the greatest benefit from the electric heater ELK 15 you should read the "For Home Owners" section in this Installation and Maintenance Instruction. ELK 15 is an electric heater that is intended for installation together with a heat pump for heating detached houses and small apartment buildings.***

***ELK 15 is a Swedish-made quality product offering long life and reliable operation.***

<p>The serial number* (95) must always be stated in all correspondence with NIBE.</p>	
069_-----	
Installation date	
Plumber	
Electrician	
<p>Insert any notes here.</p>	
Datum _____	Sign _____

\*The serial number can be found at the bottom corner on the inside of the electric heater.

This appliance is not intended for use by persons (including children) with reduced physical, sensory or mental capabilities, or lack of experience and knowledge, unless they have been given supervision or instruction concerning use of the appliance by a person responsible for their safety.

Children should be supervised to ensure that they do not play with the appliance.

Rights to make any design or technical modifications are reserved.

©NIBE 2012.

## System description

### Principle of operation

NIBE ELK 15 is an electric heater that is primarily intended for installation together with a heat pump for heating buildings.

ELK 15 contains overheat protection and contactors for external control of the two power groups 5.0 and 10.0 kW.

Time delay recommended in compliance with the Association of Swedish Electricity Utilities norms (always apply national regulations) when connected power output exceeds 6 kW.

The electric module is principally an immersion heater installed in a water container, or an electric boiler without domestic hot water heater.

The stainless electric coils and electric boiler tube are made from acid proof steel (SIS 2333), which gives a very long service life.

### Economical

A small water volume and a well insulated cassette mean small heat losses.

### Components

AV	Shut-off valve
BV	Non-return valve
CP	Circulation pump
EXP	Expansion vessel
FG	Flow line sensor
RG	Return line sensor
RV	Control valve
SÄV	Safety valve

**NOTE!** This is an outline sketch. Actual installations must be planned according to applicable standards.

See the relevant outline diagram for connection to the different heat pumps.

### System diagram

Additional heat from ELK 15 is controlled by the heat pump.

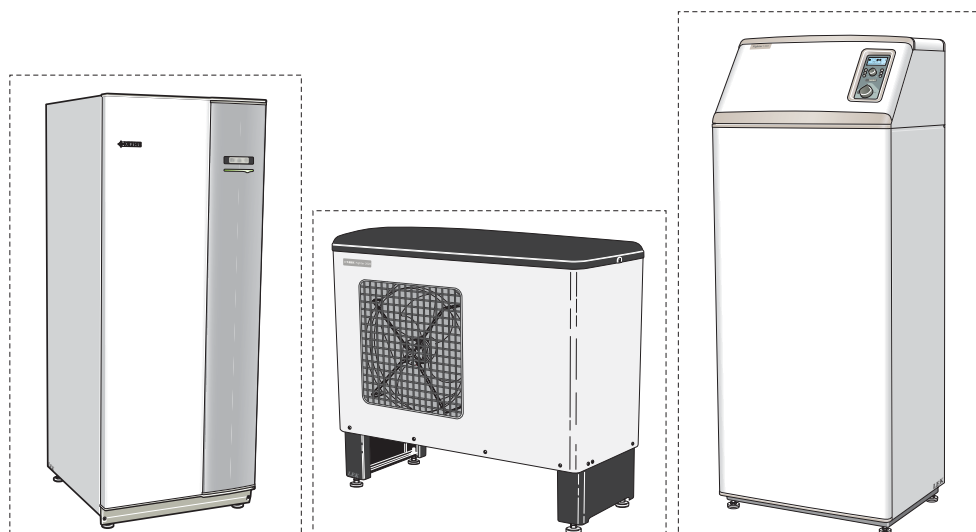
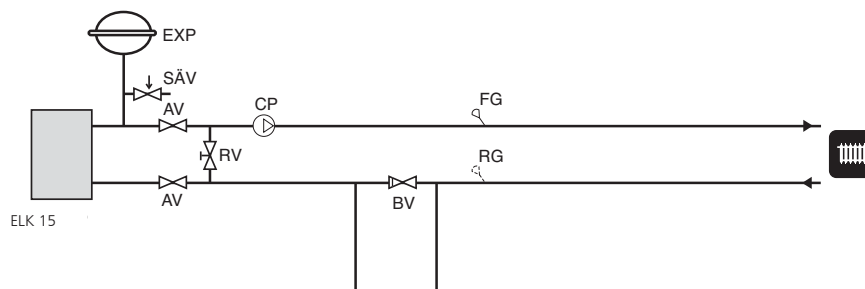

## **Operation and maintenance**

### **General**

After installing, check with the installer that the installation is in good condition. Allow the installer to show controls and functions so that you are fully aware about how to use and maintain the installation.

Check that the water pressure is correct; air may remain in the system after installing. This is why bleeding and pressure checks should be carried out again.

### **Operation**

Electrical output is controlled externally by the heat pump. This means that the electrical output is connected and disconnected by the additional heater.

### **Safety valve**

A safety valve that is installed in the heating system, in connection with the closed expansion system, must be exercised regularly, approximately 4 times per year to maintain the safety function or according to national regulations.

### **Venting**

Regularly check that there is water in the system. Air can remain in the system after installation and the radiators and boiler should be bled again. After bleeding, the pressure must be checked and water topped up if necessary.

### **Draining**

If draining the system of water, the electric module must be switched off to prevent damaging the immersion heater's electric coils.

### **Actions in the event of freeze risk**

In the event of extreme cold, no part of the heating system must be switched off, there is a risk of frost damage.

If a part of the heating system is thought to be frozen, contact the installer.

If the heating system must be switched off for a long period of time, drain the water and ensure that the immersion heater cannot be started.

## General information for the installer

### Function

Area of use for NIBE immersion heater is in combination with NIBE ground source heat pumps and air/water heat pumps. When the heating demand is greater than heat pump's capacity, the immersion heater connects automatically as additional heat. The electrical equipment is adapted to the heat pump's function.

ELK 15 contains overheating protection and contactors to externally regulate the two power steps, 5 and 10 kW. For optimum function the outputs should be binary controlled, i.e. 5, 10 and 15 kW.

If there is no operating voltage from the heat pump, the largest power stage can be force controlled via thermostat. See the wiring diagram.

### Pipe installation

The pipe installation must be carried out in accordance with applicable standards.

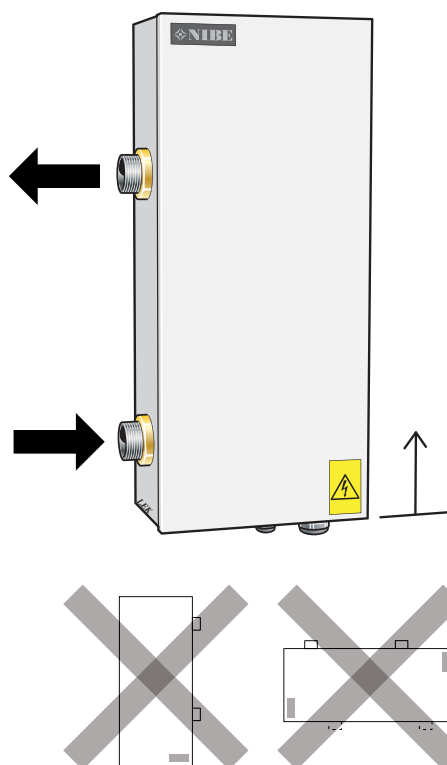

The immersion heater must be installed standing (see image above). An area of 500 mm is required in front of the immersion heater for service work. If this is not possible, detachable connections should be used.

Circulation pump must be used to ensure the flow over the immersion heater. If the heating system's valves can close the circulation completely, a by-pass must be installed to prevent the flow through the immersion heater from being stopped. When the unit is off, an approved safety valve must be installed as well as a pressure expansion vessel. The safety valves must be checked about four times a year. This is done

by quickly opening and closing the valves. The pressure is reset by filling with water.

### Electrical installation

ELK 15 must be installed via an isolator switch with a minimum breaking gap of 3 mm.

#### NOTE

*Electrical installation and service must be carried out under the supervision of a qualified electrician. Electrical installation and wiring must be carried out in accordance with the stipulations in force.*

### Power supply

The electric heater must be supplied with 4 x 6 mm<sup>2</sup> cable, 3 x 400 V AC 50Hz, fused 3 x 25 A.

The cable for the operational supply must be 5 x 1,5 mm<sup>2</sup>.

#### NOTE

*Reset the temperature limiter, it may have tripped during transport.*

#### NOTE

*In the event of any servicing all electrical supplies must be checked and disconnected. The immersion heater can be supplied with voltage from connected heat pump.*

### Draining

The system is most easily drained by installing a drain valve to the lowest point of the piping. Draining via such a valve leaves a small amount of water in the immersion heater, which is therefore drained via drain connection (71). If the unit is normally drained via the immersion heater's drain connection, install a suitable drain valve.

## Installation alternative

### Components

AV	Shut-off valve	AA5	Accessory card
BK/JK	Rock collector/Soil collector	BP6	Pressure gauge
BV	Non-return valve	BT1	Outdoor temperature sensor
CP	Circulation pump	BT6	Temperature sensor, hot water charging
ELK	Immersion heater	BT25	Temperature sensor, heating medium flow, external
EL VVB	Electric water heater	BT71	Temperature sensor, heating medium return, external
EXP	Expansion vessel	CMX	Expansion vessel
FG	Flow sensor	CP10	Accumulator tank
HR	Auxiliary relay	EB1	Immersion heater
KB	Brine	EB2	Immersion heater
LP	Charge pump	EB100	Heat pump
NK	Level vessel	EP12	Collector, brine side
RG	Return temperature sensor	EP14	Cooling module A
RV	Control valve	EP15	Cooling module B
SF	Particle filter	FL2	Safety valve, heating medium
SÄV	Safety valve	FL3	Safety valve, brine
UG	Outdoor temperature sensor	FL1X	Safety valve
VBP	Circulation pump	GP10	Circulation pump, heating medium
VP	Heat pump	HQ1X	Particle filter
VVB/ACK	Accumulator with hot water heater	KA1	Auxiliary relay, immersion heater
VVG	Hot water temperature sensor	QM11	filler valve
VXV	Three way valve, VST 11/VST 20	QM2X	Venting valve
		QM30-QM59	Shut-off valve
		QN10	Reversing valve, hot water/heating
		RMXX	Non-return valve
		RN11	Trim valve
		XD1	Connection box
		XL27-XL28	Connection, filling brine





**Electrical connection FIGHTER 1320/1330  
Without thermostat**

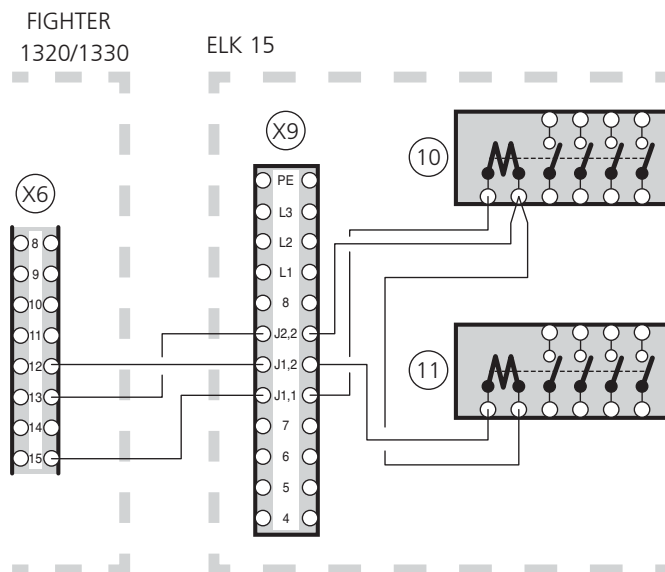

**With thermostat**

10 kW immersion heater step active in emergency mode.

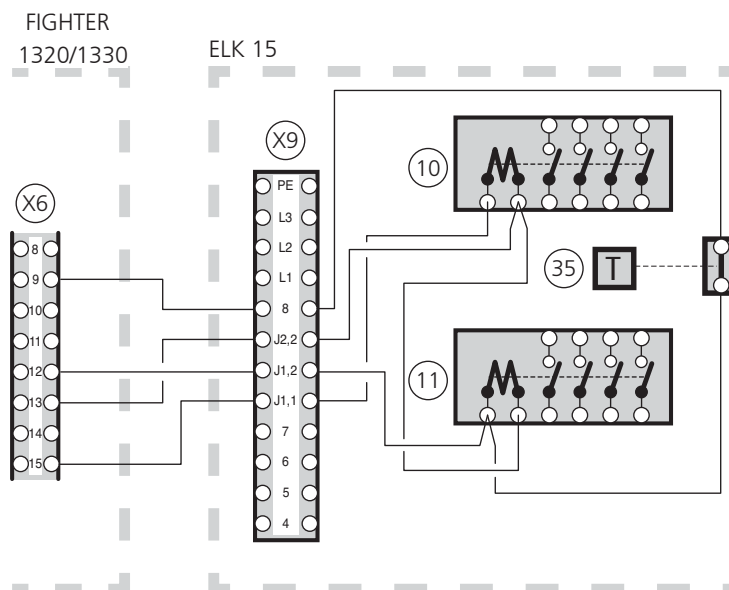

**NOTE**

*The thermostat (35) must be adjusted so that the system's highest permitted temperature is not exceeded. The adjustment must not be so great that it limits the power.*

**Electrical connection F1330****Without thermostat, 2 active electrical steps**

15 kW immersion heater step active.

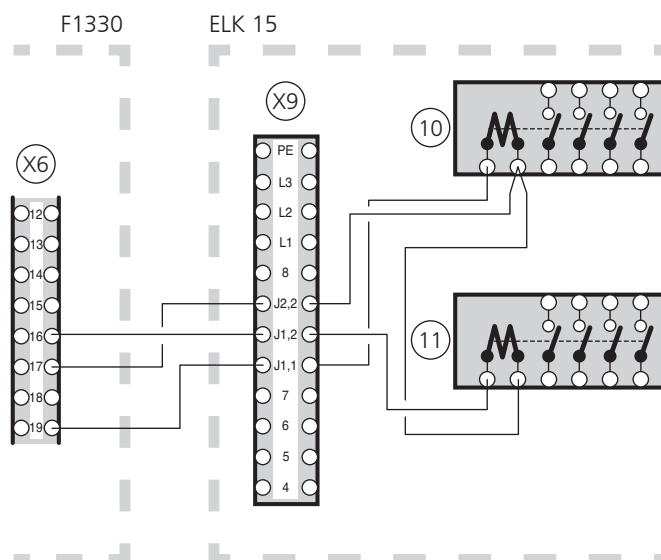
**With thermostat, 2 active electrical steps**

15 kW immersion heater step active.

10 kW immersion heater step active in emergency mode.

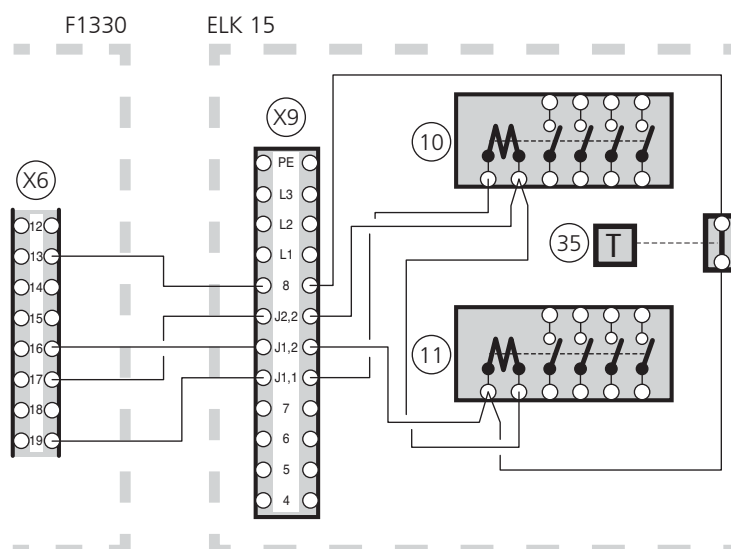
**NOTE**

The thermostat (35) must be adjusted so that the temperature above the system's highest permitted temperature is not exceeded.



**Electrical connection F1345**  
**Without thermostat, 2 active electrical steps**

15 kW immersion heater step active.

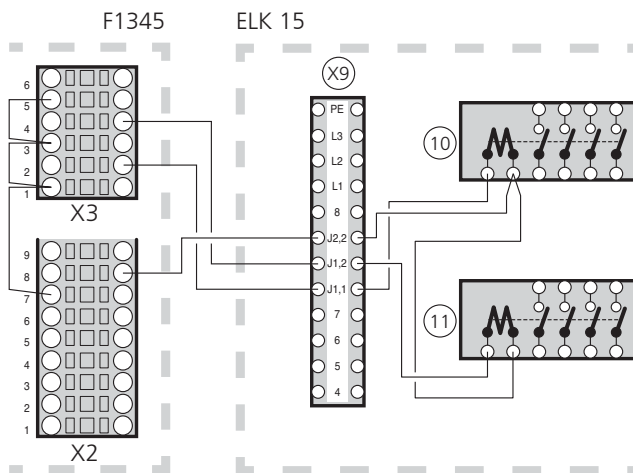

**With thermostat, 2 active electrical steps**

15 kW immersion heater step active.

10 kW immersion heater step active in emergency mode.

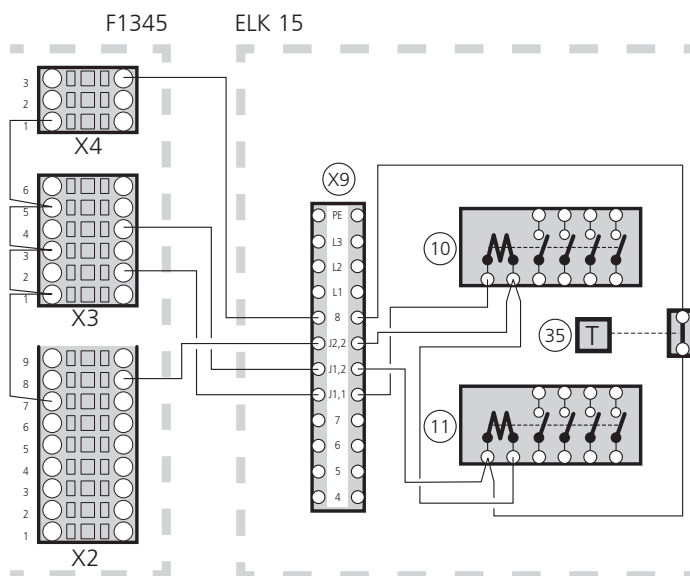

**NOTE**

*The thermostat (35) must be adjusted so that the temperature above the system's highest permitted temperature is not exceeded.*

**Electrical circuit diagram**

**Electrical circuit diagram**

To F1145

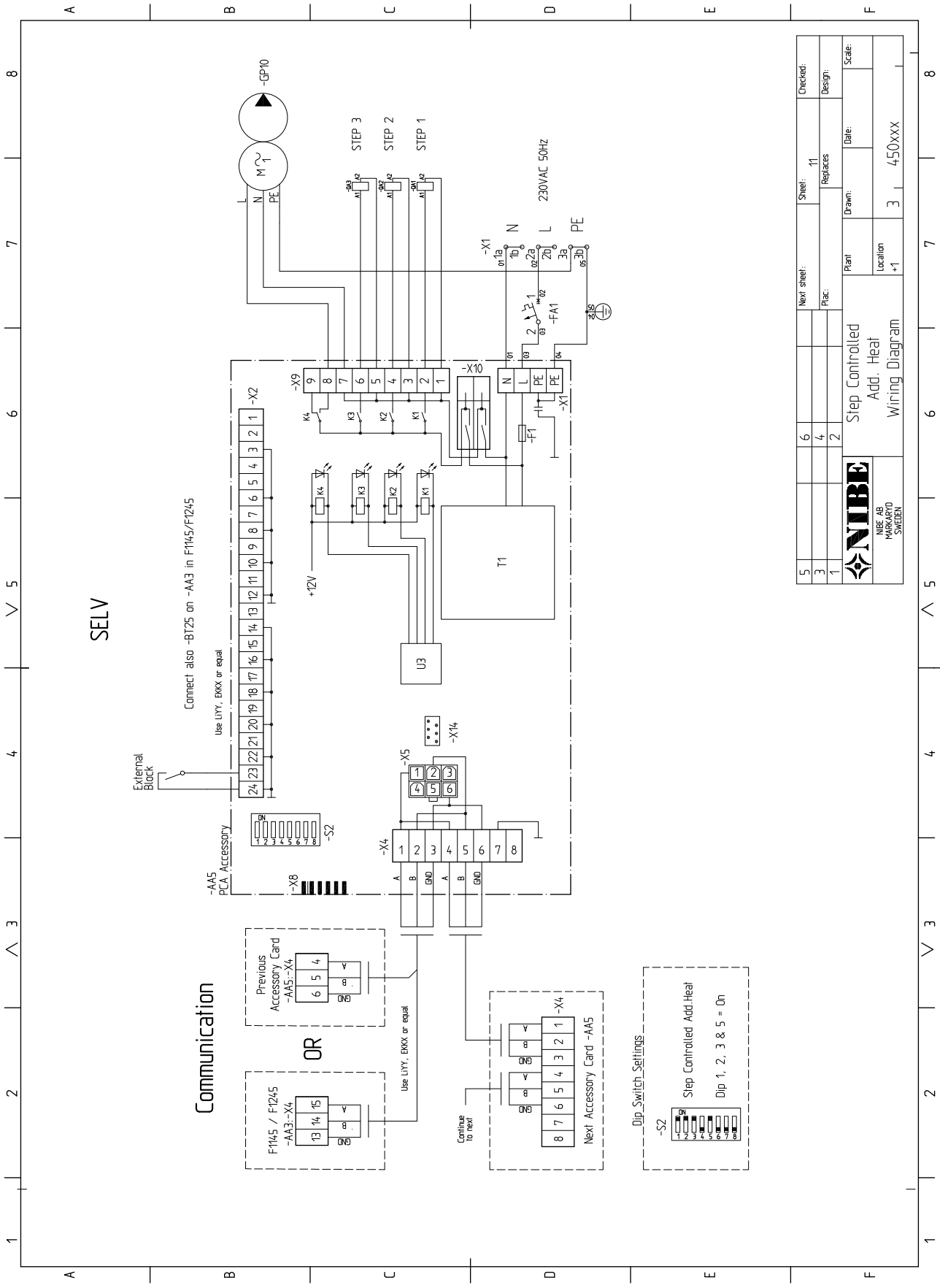

5	Next sheet:	Sheet: 11	Checked:
3	Replaces:	Design:	
1	Drawn:	Date:	Scale:
 NIBE AB HANÅRD SWELEN		Plant	
		Location	+1
Step Controlled Add'l Heat Wiring Diagram		3	450xxx

ELK 15

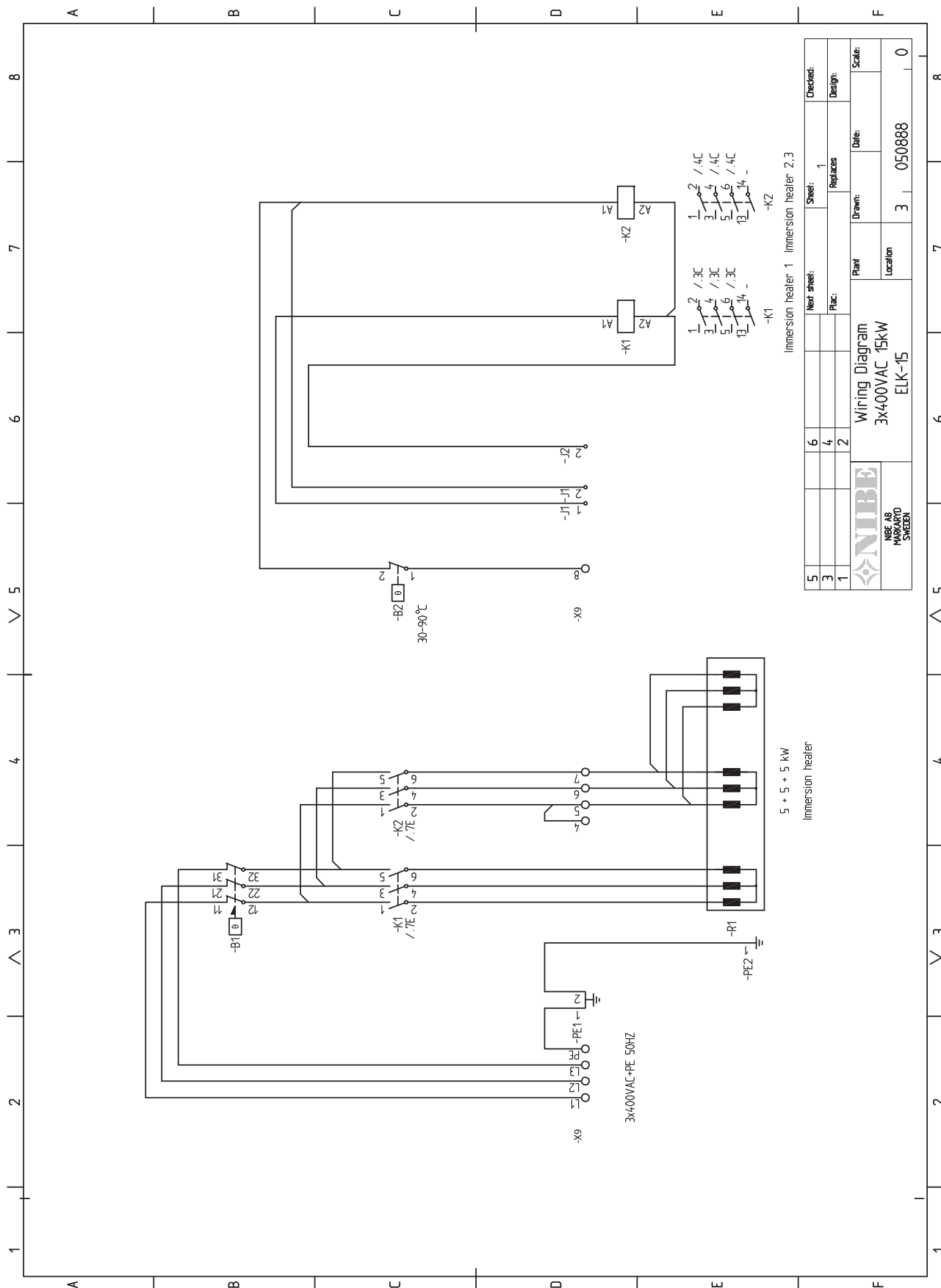

5	6	Next sheet:	Sheet:	1	Checked:
3	4	Plant:	Relays		Design:
1	2	Drawn:	Date:		Scale:
<b>Wiring Diagram</b> 3x400VAC 15kW ELK-15			Location	3	050888
<b>NIBE AB</b> HUSKVARNA SWEDEN					

## Technical specifications

### Dimensions

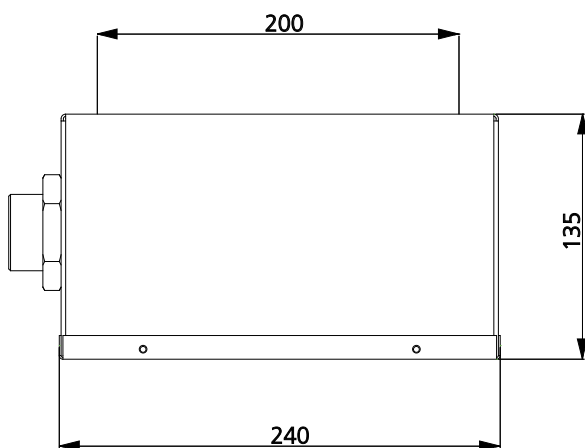
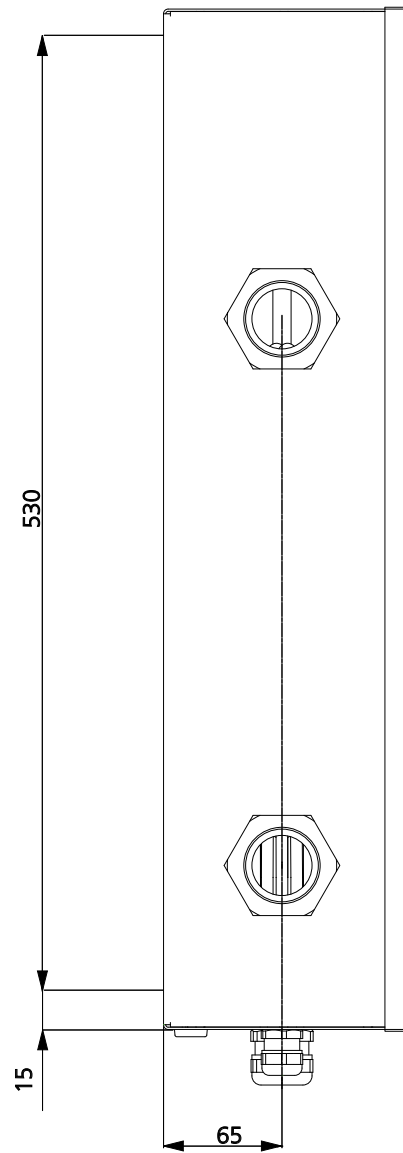
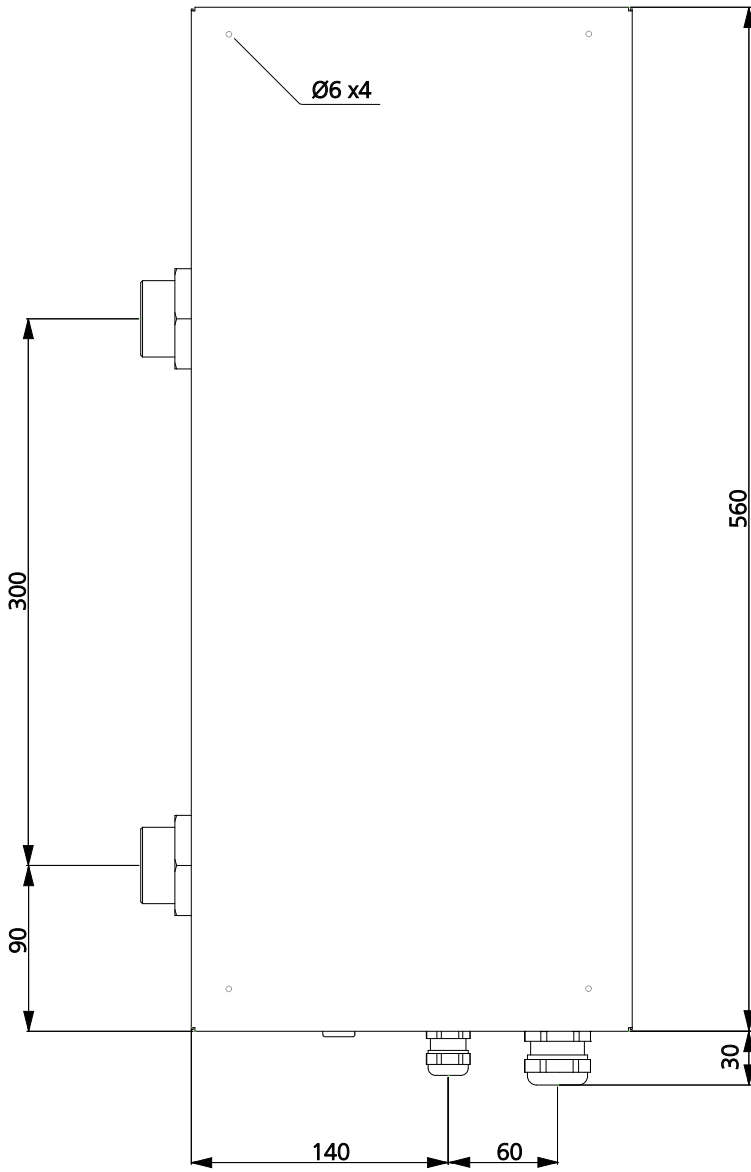



### Component positions

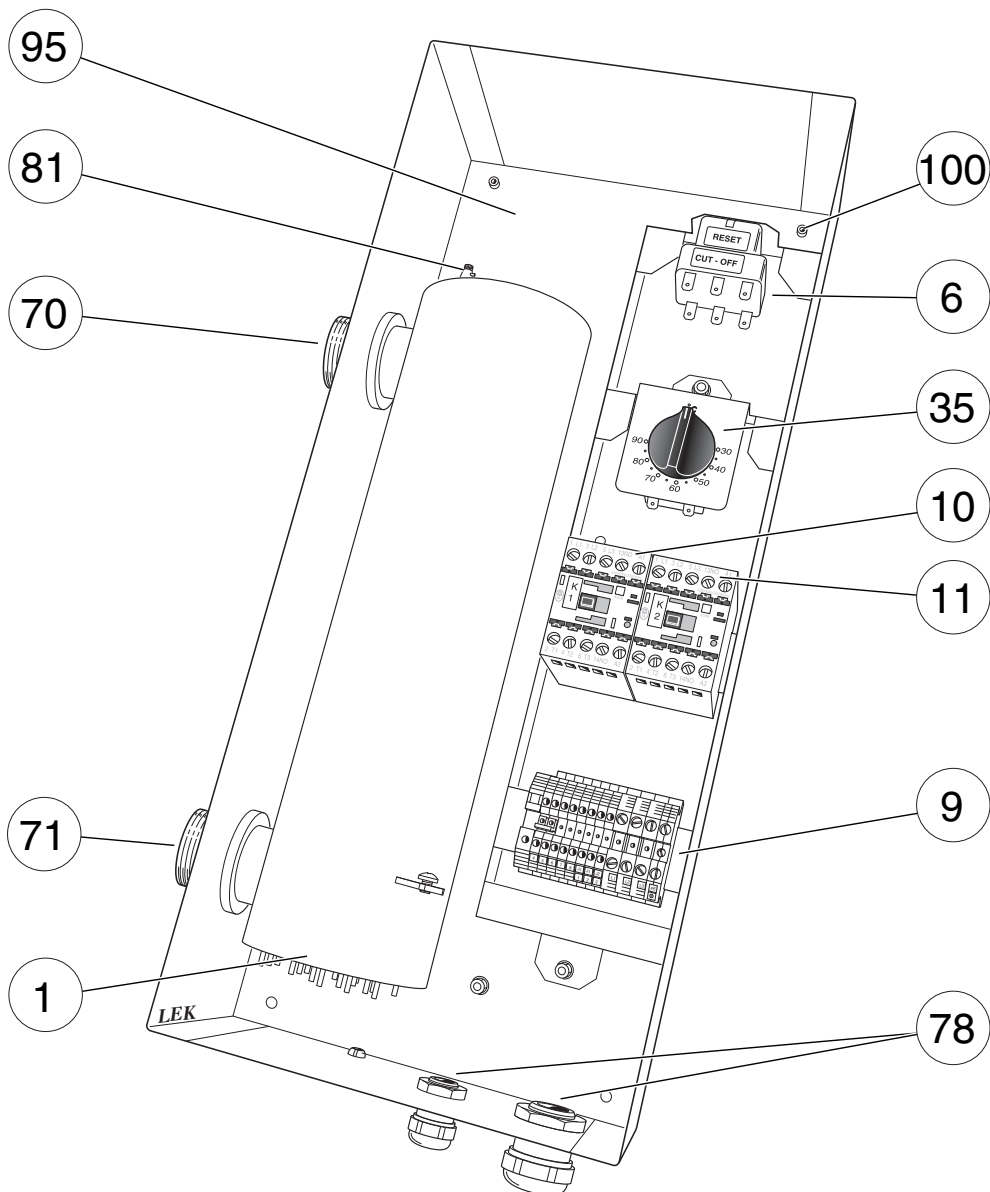

### List of components

- 1 Immersion heater (-R1)
- 6 Overheat protection (-B1)
- 9 Terminal block (-X9)
- 10 Contactor, 5,0 kW (-K1)
- 11 Contactor, 10,0 kW (-K2)
- 35 Emergency mode thermostat (-B2)
- 70 Connection, flow line, G 40
- 71 Connection, return line, G 40
- 78 Cable grommet
- 81 Venting
- 95 Sign, serial number
- 100 Installation hole 4 x (Ø 6 mm)

**Technical specifications**

Height	560 mm
Width	240 mm
Depth	135 mm
Weight	11 kg
Volume	4.5 litres
Supply voltage	3 x 400 V AC 50Hz
Output immersion heater	15 kW
Fuse immersion heater	25 A
Enclosure class	IP 44
Max permitted pressure in the boiler	0.7 MPa (7 bar)
Material immersion heater	SIS 2333 EN 1.4301
Material tube	SIS 2333 EN 1.4301
Part No.	069 022

## Dealing with malfunctions

In the event of a malfunction or disruption to normal operation, first check the points below:

### Low room temperature

- Circuit or main MCB tripped.
- Possible earth circuit-breaker tripped.
- The overheating protection has tripped. If the overheating protection has tripped, the function of the system's circulation pumps and valves must be checked. Reset by pressing in the button on the overheating protection, when the temperature has dropped below 80 °C.
- Circulation pump stopped.
- Air in boiler or system.
- The pressure is too low in the expansion vessel.
- The load monitor or some external control unit may have blocked the power output.

#### **NOTE**

*Work behind panels secured by screws may only be carried out by a qualified installation engineer.*









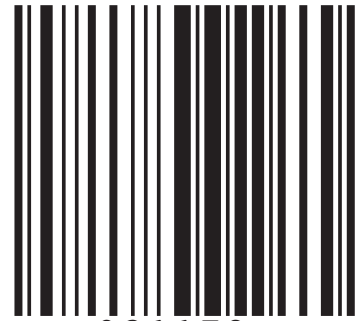

031179

**(AT)** **KNV Energietechnik GmbH**, Gahberggasse 11, 4861 Schörfling  
Tel: +43 (0)7662 8963-0 Fax: +43 (0)7662 8963-44 E-mail: mail@knv.at www.knv.at

---

**(CH)** **NIBE Wärmetechnik AG**, Winterthurerstrasse 710, CH-8247 Flurlingen  
Tel: (52) 647 00 30 Fax: (52) 647 00 31 E-mail: info@nibe.ch www.nibe.ch

---

**(CZ)** **Druzstevni zavody Drazice s.r.o.**, Drazice 69, CZ - 294 71 Benatky nad Jizerou  
Tel: +420 326 373 801 Fax: +420 326 373 803 E-mail: nibe@nibe.cz www.nibe.cz

---

**(DE)** **NIBE Systemtechnik GmbH**, Am Reiherpfahl 3, 29223 Celle  
Tel: 05141/7546-0 Fax: 05141/7546-99 E-mail: info@nibe.de www.nibe.de

---

**(DK)** **Vølund Varmeteknik A/S**, Member of the Nibe Group, Brogårdsvej 7, 6920 Videbæk  
Tel: 97 17 20 33 Fax: 97 17 29 33 E-mail: info@volundvt.dk www.volundvt.dk

---

**(FI)** **NIBE Energy Systems OY**, Juurakkotie 3, 01510 Vantaa  
Puh: 09-274 697 0 Fax: 09-274 697 40 E-mail: info@nibe.fi www.nibe.fi

---

**(FR)** **AIT France**, 10 rue des Moines, 67500 Haguenau  
Tel : 03 88 06 24 10 Fax : 03 88 06 90 15 E-mail: info@nibe.fr www.nibe.fr

---

**(GB)** **NIBE Energy Systems Ltd**, 3C Broom Business Park, Bridge Way, Chesterfield S41 9QG  
Tel: 0845 095 1200 Fax: 0845 095 1201 E-mail: info@nibe.co.uk www.nibe.co.uk

---

**(NL)** **NIBE Energietechnik B.V.**, Postbus 2, NL-4797 ZG WILLEMSTAD (NB)  
Tel: 0168 477722 Fax: 0168 476998 E-mail: info@nibenl.nl www.nibenl.nl

---

**(NO)** **ABK AS**, Brobekkveien 80, 0582 Oslo, Postadresse: Postboks 64 Vollebekk, 0516 Oslo  
Tel. sentralbord: +47 02320 E-mail: post@abkklima.no www.nibeenergysystems.no

---

**(PL)** **NIBE-BIAWAR Sp. z o. o.** Aleja Jana Pawła II 57, 15-703 BIAŁYSTOK  
Tel: 085 662 84 90 Fax: 085 662 84 14 E-mail: sekretariat@biawar.com.pl www.biawar.com.pl

---

**(RU)** © "EVAN" 17, per. Boynovskiy, Nizhny Novgorod  
Tel./fax +7 831 419 57 06 E-mail: info@evan.ru www.nibe-evan.ru

---

**NIBE AB Sweden**, Box 14, Hannabadsvägen 5, SE-285 21 Markaryd  
Tel: +46-(0)433-73 000 Fax: +46-(0)433-73 190 E-mail: info@nibe.se www.nibe.eu

